

# Delta Gen 2

## Recessed Downlight DALI

Open Plan



Escape Route



180 Lumens	2 Watts	5000K	Recessed Mounting
LiFePO4 Battery	Class II	IP 40	6Y Warranty

### Materials

Lamp Head: Die-Cast Aluminium  
Lamp Trim: ABS  
Remote Pack: ABS

Standard Colour: White - RAL 9016  
Alternative Colour: Black - RAL 9017  
Add **/BL** to Order Code

### Warranty

Standard Warranty: 6 Years  
Alternative Warranty: 10 Years  
Add **/10Y** to order code

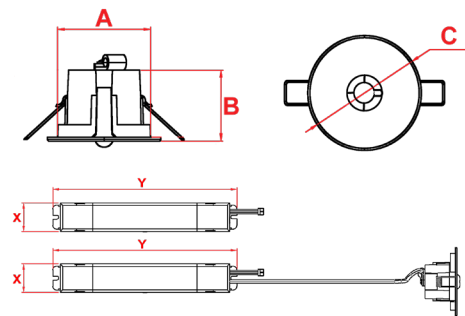

Order Code	<b>DE2NM3/L2W/**/DA</b>
Mode of operation	Non-Maintained
DALI Interface	For Controlled Monitoring and Reporting
Emergency duration	3 hours
Input voltage	230/240V (207VAC - 264VAC) 50/60Hz
Power consumption	2VA, I <sub>nom</sub> = 8mA (Full Battery)
Battery type	Rechargeable LiFePO4 Battery 3.2V 3.6Ah
Battery low voltage cut off	2.6V DC
Battery discharge current @ 3.2V DC	0.67A
Lamp	2 Watt
Lamp colour	5000K
Lamp lumen level in emergency	180 lm
Nominal lamp voltage	V <sub>rated</sub> = 3V DC
Nominal lamp current	I <sub>rated</sub> = 0.53A CC
Nominal lamp power	P <sub>rated</sub> = 2W
Maximum output voltage with no lamp connected	U-OUT = 10VDC
Ingress Protection	IP40
Cable entry	Recessed Pack
Incoming Mains cable size cross sectional area	1.5mm <sup>2</sup> - 2.5mm <sup>2</sup> single conductor
Incoming DALI Comms cable size cross sectional	1.5mm <sup>2</sup> single conductor
Cutout Size	48mm
Ceiling Void	200mm
Luminaire class	Class II
Product Weight	0.50 Kg
Packaging Weight	0.05Kg
Standards	EN61347-2-7, EN61347-2-13, EN 60598-2-22, EN 55015
Environment	0°C to 45°C up to 80% relative humidity.

System	Order Code	Mode of Operation	Battery	Battery P/N	Lumens (Emergency)	Dimensions (mm)				
						A	B	C	X	Y
DALI	DE2NM3/L2W/**/DA	Non-Maintained	3.2V, 3.6Ah LiFePO4	70268	180	45	34	55	35	196
Alternative Systems Available: Specification Sheets Available Upon Request										
Standalone	DENM3/L2W/**	Non-Maintained	6.4V, 1.5Ah LiFePO4	70267	200	45	34	55	35	196
DALI Wireless	DENM3/LED3W/DAW	Non-Maintained	6.4V, 3.2Ah LiFePO4	70259	400	45	34	55	40	215
Self-Test	DE2NM3/L2W/**/ST	Non-Maintained	3.2V, 3.6Ah LiFePO4	70268	180	45	34	55	35	196

\*\* - Add OP for Open Plan/Symmetrical Fitting  
- Add ES for Escape Route/Asymmetrical Fitting